

Series TY-B and TY-FRB Sprinklers Alternate Materials Of Construction Stainless Steel, SMO, and Titanium

General Description

The Tyco® Series TY-B and TY-FRB Sprinklers described in this data sheet are corrosion resistant sprinklers designed for use in commercial occupancies where corrosive atmospheres may exist. The TY-B with its 5 mm diameter heat sensitive glass bulb is rated standard response, whereas the TY-FRB with its 3 mm diameter heat sensitive glass bulb is rated quick response.

The alternate materials of construction for the TY-B and TY-FRB Sprinklers, i.e. Stainless Steel, SMO, or Titanium are utilized to extend the life of a sprinkler beyond that which might be expected of copper alloy sprinklers exposed to corrosive atmospheres. Although corrosion resistant sprinklers have passed the standard corrosion tests of the applicable approval agencies, the testing is not representative of all possible corrosive atmospheres. Consequently, it is recommended that the end user be consulted with respect to the suitability of these alternate materials of construction for any given corrosive environment. The effects of ambient temperature, concentration of chemicals, and gas/chemical velocity, should be considered, as a minimum, along with the corrosive nature of the



Upright and Pendent



Conventional



Horizontal Sidewall



Vertical Sidewall



Recessed Pendent



Recessed Horizontal Sidewall

IMPORTANT

Always refer to Technical Data Sheet TFP700 for the "INSTALLER WARNING" that provides cautions with respect to handling and installation of sprinkler systems and components. Improper handling and installation can permanently damage a sprinkler system or its components and cause the sprinkler to fail to operate in a fire situation or cause it to operate prematurely.

chemical to which the sprinklers will be exposed.

Pendent and Upright Sprinklers:

The pendent and upright sprinklers are standard coverage spray sprinklers available in either 5.6 or 8.0 K-factor. The recessed version is intended for use in areas with a finished ceiling. The two-piece Style 10 (1/2 inch NPT) or Style 40 (3/4 inch NPT) Recessed Escutcheons provide 1/2 inch (12.7 mm) of recessed adjustment or 3/4 inch (19.1 mm) of total adjustment from the flush pendent position. The adjustment provided by the Recessed Escutcheon reduces the accuracy to which the fixed pipe drops to the sprinklers must be cut.

Conventional Sprinklers:

The 5.6 or 8.0 K-factor conventional sprinklers are intended to be installed either pendent or upright, and in either position, they produce a spherical water discharge pattern with approximately 50% of the discharge upwards and approximately 50% of the discharge directed downwards.

Conventional sprinklers are generally used with Ordinary and Extra High hazard Class Systems as defined by the automatic sprinkler system installation rules of the country and authority having jurisdiction. The NFPA permits the use of conventional sprinklers (old style sprinklers) where special construction features require a unique water distribution; for fur vaults; or, replacement of similar sprinklers that had been installed prior to 1955.

Sidewall Sprinklers:

The horizontal and vertical sidewall sprinklers are designed for installation along a wall or side of a beam and just beneath a smooth ceiling. Sidewall sprinklers are commonly used instead of pendent and upright sprinklers due to aesthetics or building construction considerations, where piping across the ceiling is not desirable.

A recessed version of the horizontal sidewall sprinkler can be achieved by using the Style 10 Recessed Escutcheon.

WARNINGS

The Series TY-B and TY-FRB Sprinklers described herein must be installed and maintained in compliance with this document, as well as with the applicable standards of the National Fire Protection Association, in addition to the standards of any other authorities having jurisdiction. Failure to do so may impair the performance of these devices.

The owner is responsible for maintain-

ing their fire protection system and devices in proper operating condition. The installing contractor or sprinkler manufacturer should be contacted with any questions.

Model/Sprinkler Identification Numbers

Stainless Steel-Standard Response

TY8191 -	Upright	5.6K, 1/2" NPT
TY8291 -	Pendent	5.6K, 1/2" NPT
TY9191 -	Upright	8.0K, 3/4" NPT
TY9291 -	Pendent	8.0K, 3/4" NPT
TY8691-	C/UP	5.6K, 1/2" NPT
TY9691-	C/UP	8.0K, 3/4" NPT
TY8391-	HSW	5.6K, 1/2" NPT
TY8491-	VSW	5.6K, 1/2" NPT

Stainless Steel-Quick Response

TY8181 -	Upright	5.6K, 1/2" NPT
TY8281 -	Pendent	5.6K, 1/2" NPT
TY9181 -	Upright	8.0K, 3/4" NPT
TY9281 -	Pendent	8.0K, 3/4" NPT
TY8681-	C/UP	5.6K, 1/2" NPT
TY9681-	C/UP	8.0K, 3/4" NPT
TY8381-	HSW	5.6K, 1/2" NPT
TY8481-	VSW	5.6K, 1/2" NPT

SMO-Standard Response

TY8192 -	Upright	5.6K, 1/2" NPT
TY8292 -	Pendent	5.6K, 1/2" NPT
TY8692-	C/UP	5.6K, 1/2" NPT
TY8392-	HSW	5.6K, 1/2" NPT
TY8492-	VSW	5.6K, 1/2" NPT

SMO-Quick Response

TY8182 -	Upright	5.6K, 1/2" NPT
TY8282 -	Pendent	5.6K, 1/2" NPT
TY8682-	C/UP	5.6K, 1/2" NPT
TY8382-	HSW	5.6K, 1/2" NPT
TY8482-	VSW	5.6K, 1/2" NPT

Titanium-Standard Response

TY8193 -	Upright	5.6K, 1/2" NPT
TY8293 -	Pendent	5.6K, 1/2" NPT
TY8693-	C/UP	5.6K, 1/2" NPT
TY8393-	HSW	5.6K, 1/2" NPT
TY8493-	VSW	5.6K, 1/2" NPT

Titanium-Quick Response

TY8183 -	Upright	5.6K, 1/2" NPT
TY8283 -	Pendent	5.6K, 1/2" NPT
TY8683-	C/UP	5.6K, 1/2" NPT
TY8383-	HSW	5.6K, 1/2" NPT
TY8483-	VSW	5.6K, 1/2" NPT

Technical Data

Approvals

Refer to Table A, B, C, and D.

Maximum Working Pressure

175 psi (12,1 bar)

Discharge Coefficient

K = 5.6 GPM/psi^{1/2} (80,6 LPM/bar^{1/2})
K = 8.0 GPM/psi^{1/2} (115,2 LPM/bar^{1/2})

Temperature Ratings

Refer to Table A, B, C, and D.

Physical Characteristics

• Stainless Steel

The frame is free machining ANC4A Stainless Steel, per BS 3146 PT 2. The Deflector is Type 316L (UNS 31603) Stainless Steel per ASTM A479/479M or BS EN 10088 WN1.4401/4404. The Compression Screw and Button are Type 316L (UNS 31603) Stainless Steel per ASTM A479/479M or BS EN 10088 WN1.4404. The Sealing Assembly consists of a Disc Spring that is sealed on both its inside and outside faces with a Teflon* Gasket. The Disc Spring is 1/2 Hard Beryllium Nickel (UNS NO3360) Gold Plated per MIL G-45204, Type 3, Class 2. The Bulb is Glass.

• SMO

The Frame, Deflector, Compression Screw, and Button are 254 SMO** Duplex Stainless Steel per UNS S31254. The Sealing Assembly consists of a Disc Spring that is sealed on both its inside and outside faces with a Teflon* Gasket. The Disc Spring is 1/2 Hard Beryllium Nickel (UNS NO3360) Gold Plated per MIL G-45204, Type 3, Class 2. The Bulb is Glass.

• Titanium

The Frame is Titanium, Grade 2 per UNS R50400. The Deflector is Titanium, Grade 2 per ASTM B265-03. The Compression Screw is Titanium, Grade 5 per ASTM B348-03. The Button is Titanium, Grade 2 per ASTM B348. The Sealing Assembly consists of a Disc Spring that is sealed on both its inside and outside faces with a Teflon* Gasket. The Disc Spring is Titanium 6AL/4V Ti per AMS4911J. The Bulb is Glass.

* Teflon is a DuPont registered trademark.

** 254 SMO is a Avesta Sheffield registered trademark.

MODEL K RESPONSE	TYPE	TEMP. RATING	BULB LIQUID COLOR	SPRINKLER MATERIAL		
				STAINLESS STEEL	SMO	TITANIUM
TY-B 5.6 1/2" NPT SR	PENDENT and UPRIGHT	135°F/57°C	Orange	1, 2, 3, 4		3, 4
		155°F/68°C	Red			
		175°F/79°C	Yellow			
		200°F/93°C	Green			
		286°F/141°C	Blue			
		360°F/182°C	Mauve			
	RECESSED PENDENT* Figure 13	135°F/57°C	Orange	1, 2		NAS
		155°F/68°C	Red			
		175°F/79°C	Yellow			
		200°F/93°C	Green			
		286°F/141°C	Blue			
TY-B 8.0 3/4" NPT SR	PENDENT and UPRIGHT	135°F/57°C	Orange	1, 2, 3, 4		N/A
		155°F/68°C	Red			
		175°F/79°C	Yellow			
		200°F/93°C	Green			
		286°F/141°C	Blue			
		360°F/182°C	Mauve			
	RECESSED PENDENT* Figure 14	135°F/57°C	Orange	1, 2		
		155°F/68°C	Red			
		175°F/79°C	Yellow			
		200°F/93°C	Green			
		286°F/141°C	Blue			

NOTES:

1. Listed by Underwriters Laboratories, Inc. (UL).
2. Listed by Underwriters Laboratories, Inc. for use in Canada (C-UL).
3. Loss Prevention Certification Board Approved (LPCB Ref. No. 007q/01 & 007q/02).
Loss Prevention Certification Board EC Certificate of Conformity — 0832-CPD-2020.
4. Lloyd's Register Certificate of Fire Approval — SAS F060123.
Lloyd's Register EC Type Examination (Module B) Certificate — MED0650147.
Lloyd's Register EC (Module D) Certificate of Conformity — MED 0750238.

* Installed with Style 10 (1/2" NPT) Recessed Escutcheon.

NAS: No Approval Status.

N/A: Not Available.

TABLE A
LABORATORY LISTINGS AND APPROVALS
SERIES TY-B STANDARD RESPONSE
5.6 & 8.0 K-FACTOR PENDENT AND UPRIGHT SPRINKLERS

MODEL K RESPONSE	TYPE	TEMP. RATING	BULB LIQUID COLOR	SPRINKLER MATERIAL		
				STAINLESS STEEL	SMO	TITANIUM
TY-B 5.6 1/2" NPT QR	PENDENT and UPRIGHT	135°F/57°C	Orange	1, 2, 3, 4		3, 4
		155°F/68°C	Red			
		175°F/79°C	Yellow			
		200°F/93°C	Green			
		286°F/141°C	Blue			
	RECESSED PENDENT* Figure 13	135°F/57°C	Orange	1, 2		NAS
		155°F/68°C	Red			
		175°F/79°C	Yellow			
		200°F/93°C	Green			
		286°F/141°C	Blue			
TY-B 8.0 3/4" NPT QR	PENDENT and UPRIGHT	135°F/57°C	Orange	1, 2, 3, 4		N/A
		155°F/68°C	Red			
		175°F/79°C	Yellow			
		200°F/93°C	Green			
		286°F/141°C	Blue			
	RECESSED PENDENT* Figure 14	135°F/57°C	Orange	1, 2		N/A
		155°F/68°C	Red			
		175°F/79°C	Yellow			
		200°F/93°C	Green			
		286°F/141°C	Blue			

NOTES:

1. Listed by Underwriters Laboratories, Inc. (UL).
 2. Listed by Underwriters Laboratories, Inc. for use in Canada (C-UL).
 3. Loss Prevention Certification Board Approved (LPCB Ref. No. 007q/01 & 007q/02).
Loss Prevention Certification Board EC Certificate of Conformity — 0832-CPD-2020.
 4. Lloyd's Register Certificate of Fire Approval — SAS F060123.
Lloyd's Register EC Type Examination (Module B) Certificate — MED0650147.
Lloyd's Register EC (Module D) Certificate of Conformity — MED 0750238.
- * Installed with Style 10 (1/2" NPT) Recessed Escutcheon.
NAS: No Approval Status.
N/A: Not Available.

**TABLE B
LABORATORY LISTINGS AND APPROVALS
SERIES TY-FRB QUICK RESPONSE
5.6 & 8.0 K-FACTOR PENDENT AND UPRIGHT SPRINKLERS**

MODEL K RESPONSE	TYPE	TEMP. RATING	BULB LIQUID COLOR	SPRINKLER MATERIAL		
				STAINLESS STEEL	SMO	TITANIUM
TY-B 5.6 1/2" NPT SR	HORIZONTAL SIDEWALL	135°F/57°C	Orange	3, 4		
		155°F/68°C	Red			
		175°F/79°C	Yellow			
		200°F/93°C	Green			
		286°F/141°C	Blue			
		360°F/182°C	Mauve			
	RECESSED HSW* Figure 15	135°F/57°C	Orange	NAS		
		155°F/68°C	Red			
		175°F/79°C	Yellow			
		200°F/93°C	Green			
		286°F/141°C	Blue			
		360°F/182°C	Mauve			
	VERTICAL SIDEWALL	135°F/57°C	Orange	3, 4		
		155°F/68°C	Red			
		175°F/79°C	Yellow			
		200°F/93°C	Green			
		286°F/141°C	Blue			
		360°F/182°C	Mauve			
TY-B 5.6 1/2" NPT QR	HORIZONTAL SIDEWALL	135°F/57°C	Orange	3, 4		
		155°F/68°C	Red			
		175°F/79°C	Yellow			
		200°F/93°C	Green			
		286°F/141°C	Blue			
		360°F/182°C	Mauve			
	RECESSED HSW* Figure 15	135°F/57°C	Orange	NAS		
		155°F/68°C	Red			
		175°F/79°C	Yellow			
		200°F/93°C	Green			
		286°F/141°C	Blue			
		360°F/182°C	Mauve			
	VERTICAL SIDEWALL	135°F/57°C	Orange	3, 4		
		155°F/68°C	Red			
		175°F/79°C	Yellow			
		200°F/93°C	Green			
		286°F/141°C	Blue			
		360°F/182°C	Mauve			

NOTES:

1. Listed by Underwriters Laboratories, Inc. (UL).
2. Listed by Underwriters Laboratories, Inc. for use in Canada (C-UL).
3. Loss Prevention Certification Board Approved (LPCB Ref. No. 007q/01 & 007q/02).
Loss Prevention Certification Board EC Certificate of Conformity — 0832-CPD-2020.
4. Lloyd's Register Certificate of Fire Approval — SAS F060123.
Lloyd's Register EC Type Examination (Module B) Certificate — MED0650147.
Lloyd's Register EC (Module D) Certificate of Conformity — MED 0750238.

* Installed with Style 10 (1/2" NPT) Recessed Escutcheon.

NAS: No Approval Status.

N/A: Not Available.

TABLE C
LABORATORY LISTINGS AND APPROVALS
SERIES TY-B STANDARD RESPONSE AND SERIES TY-FRB QUICK RESPONSE
5.6 K-FACTOR HORIZONTAL SIDEWALL AND VERTICAL SIDEWALL SPRINKLERS

MODEL K RESPONSE	TYPE	TEMP. RATING	BULB LIQUID COLOR	SPRINKLER MATERIAL		
				STAINLESS STEEL	SMO	TITANIUM
TY-B 5.6 1/2" NPT SR	C/UP	135°F/57°C	Orange	3, 4		
		155°F/68°C	Red			
		175°F/79°C	Yellow			
		200°F/93°C	Green			
		286°F/141°C	Blue			
		360°F/182°C	Mauve			
TY-B 5.6 1/2" NPT QR	C/UP	135°F/57°C	Orange			
		155°F/68°C	Red			
		175°F/79°C	Yellow			
		200°F/93°C	Green			
		286°F/141°C	Blue			
TY-B 8.0 3/4" NPT SR	C/UP	135°F/57°C	Orange			
		155°F/68°C	Red			
		175°F/79°C	Yellow			
		200°F/93°C	Green			
		286°F/141°C	Blue			
		360°F/182°C	Mauve			
TY-B 8.0 3/4" NPT QR	C/UP	135°F/57°C	Orange			
		155°F/68°C	Red			
		175°F/79°C	Yellow			
		200°F/93°C	Green			
		286°F/141°C	Blue			

NOTES:

1. Listed by Underwriters Laboratories, Inc. (UL).
2. Listed by Underwriters Laboratories, Inc. for use in Canada (C-UL).
3. Loss Prevention Certification Board Approved (LPCB Ref. No. 007q/01 & 007q/02).
Loss Prevention Certification Board EC Certificate of Conformity — 0832-CPD-2020.
4. Lloyd's Register Certificate of Fire Approval — SAS F060123.
Lloyd's Register EC Type Examination (Module B) Certificate — MED0650147.
Lloyd's Register EC (Module D) Certificate of Conformity — MED 0750238.

* Installed with Style 10 (1/2" NPT) Recessed Escutcheon.

NAS: No Approval Status.

N/A: Not Available.

TABLE D
LABORATORY LISTINGS AND APPROVALS
SERIES TY-B STANDARD RESPONSE AND SERIES TY-FRB QUICK RESPONSE
5.6 & 8.0 K-FACTOR CONVENTIONAL (C/UP) SPRINKLERS

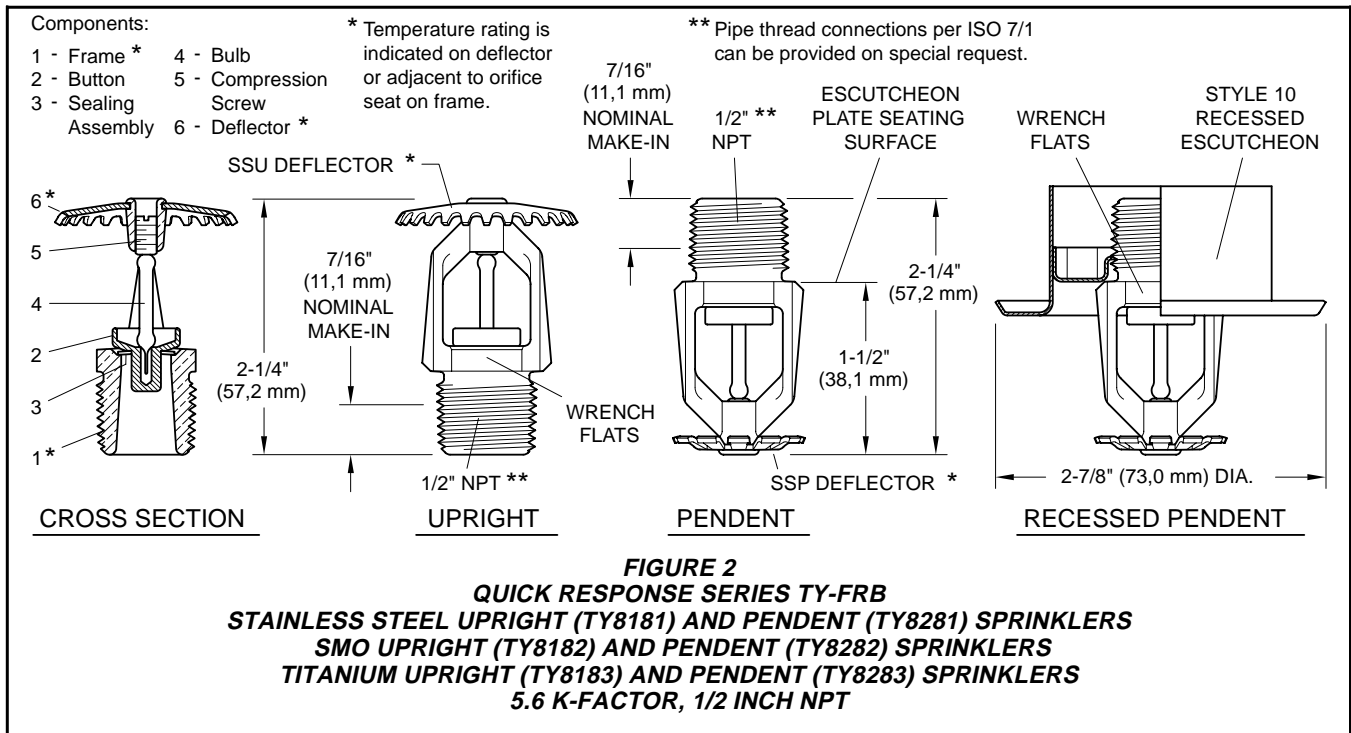
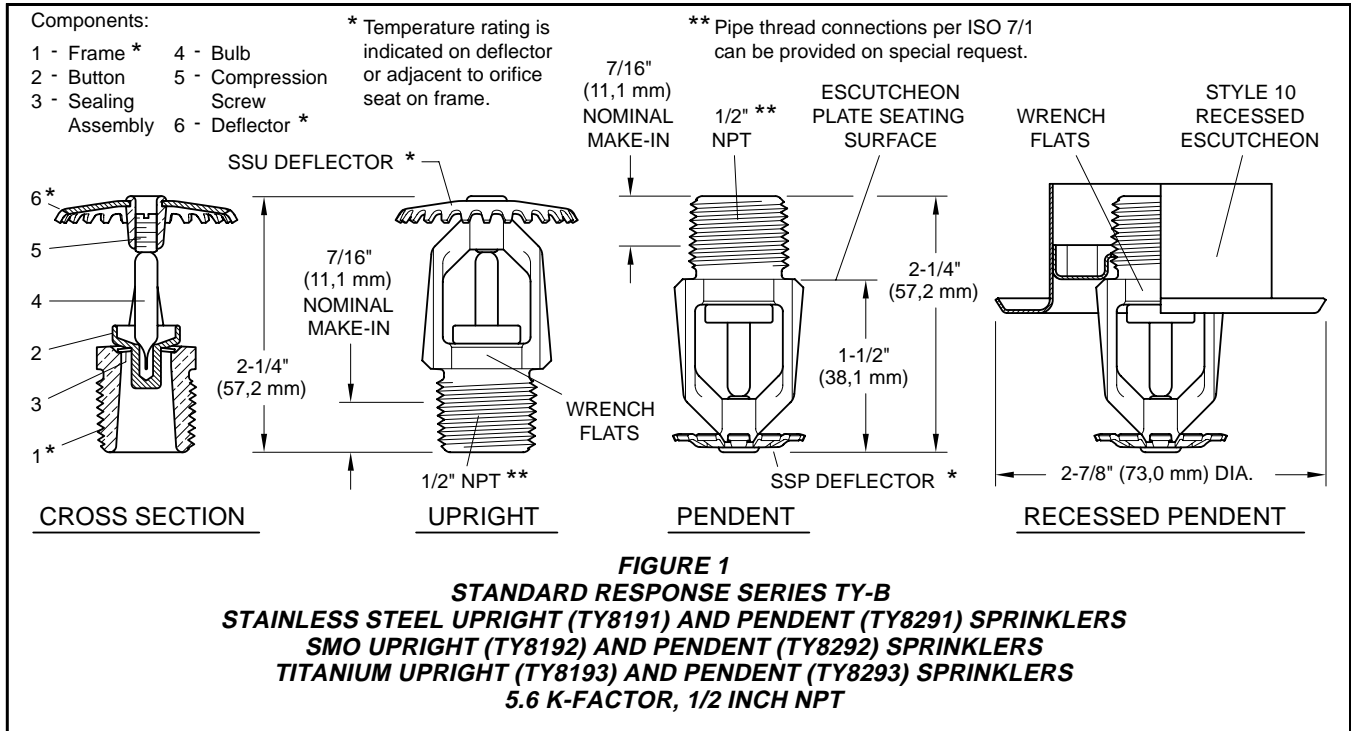

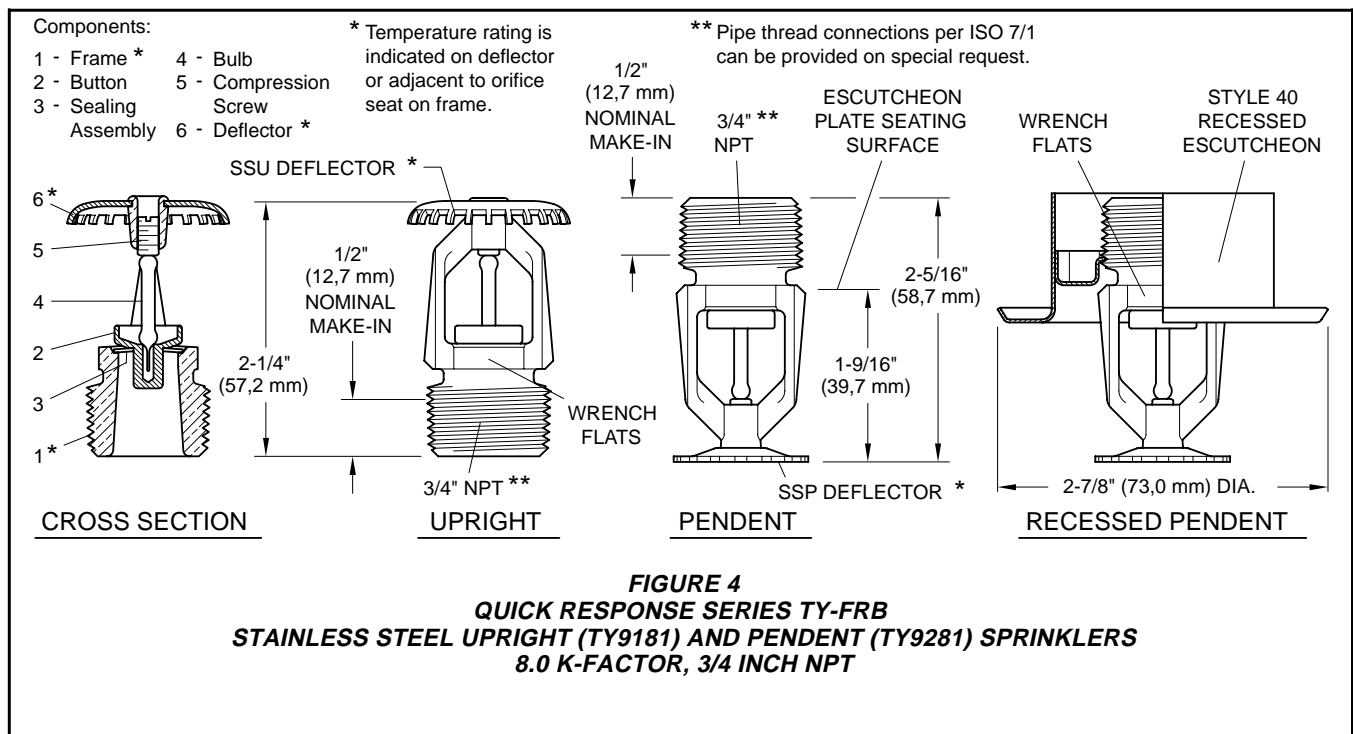
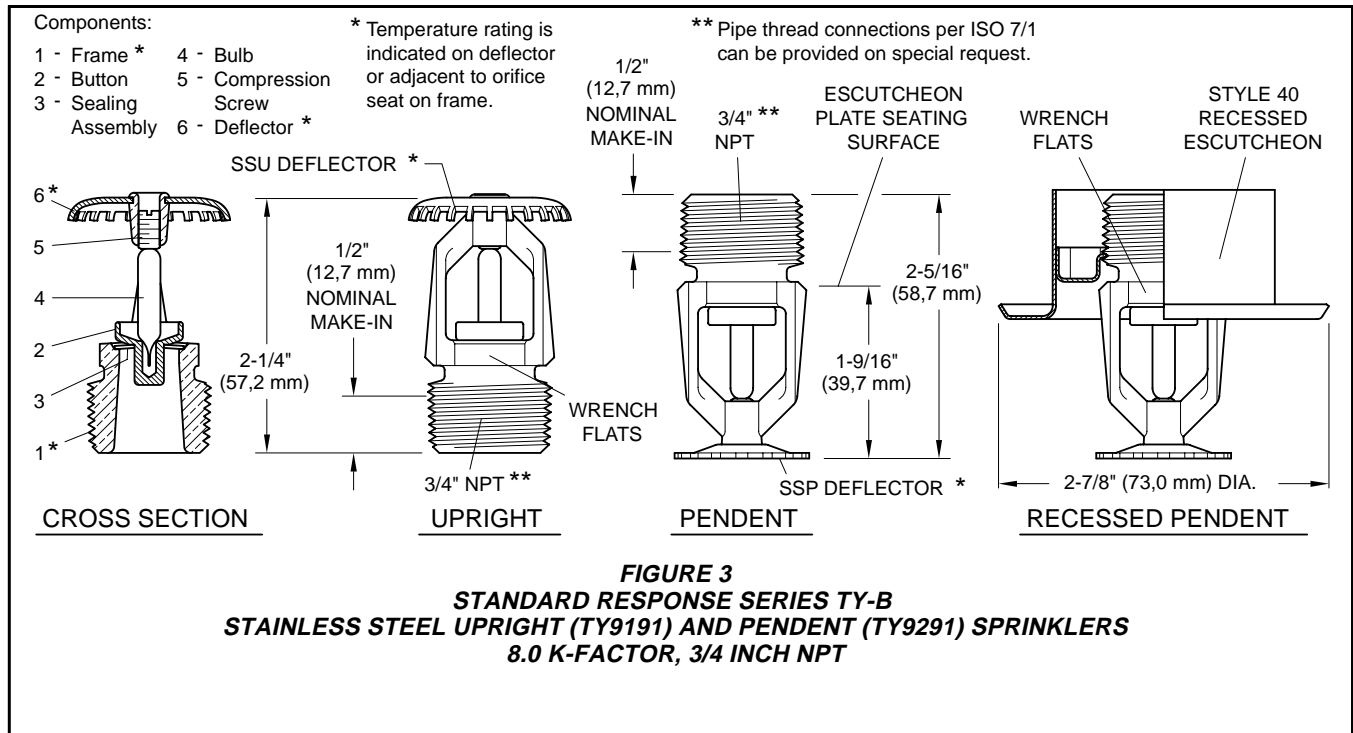

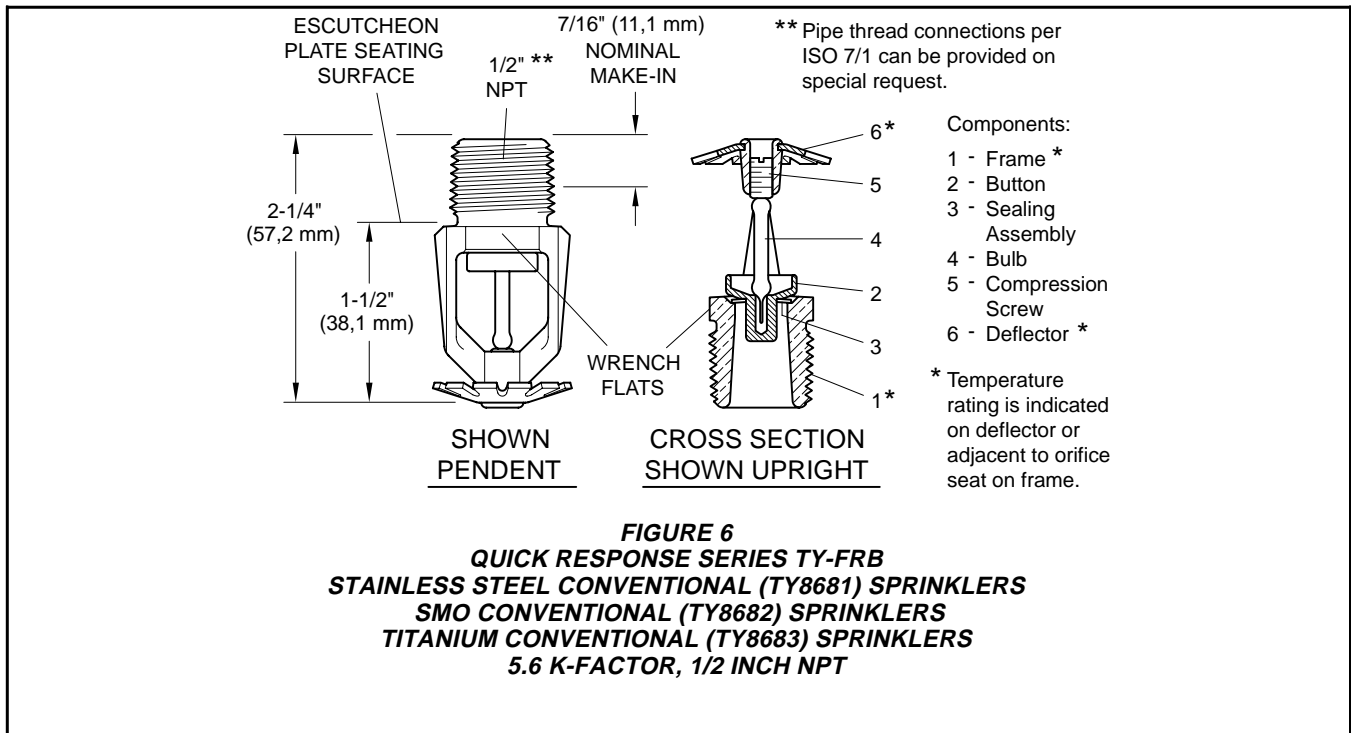
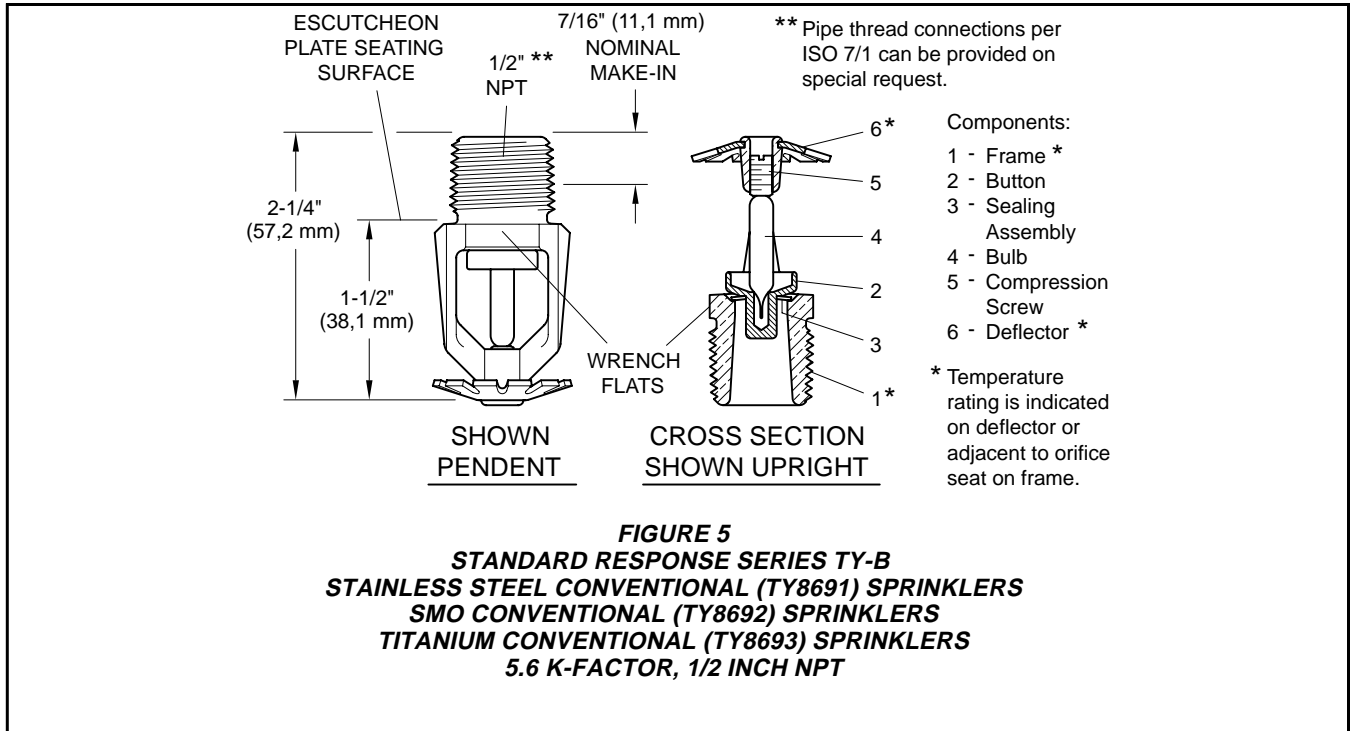

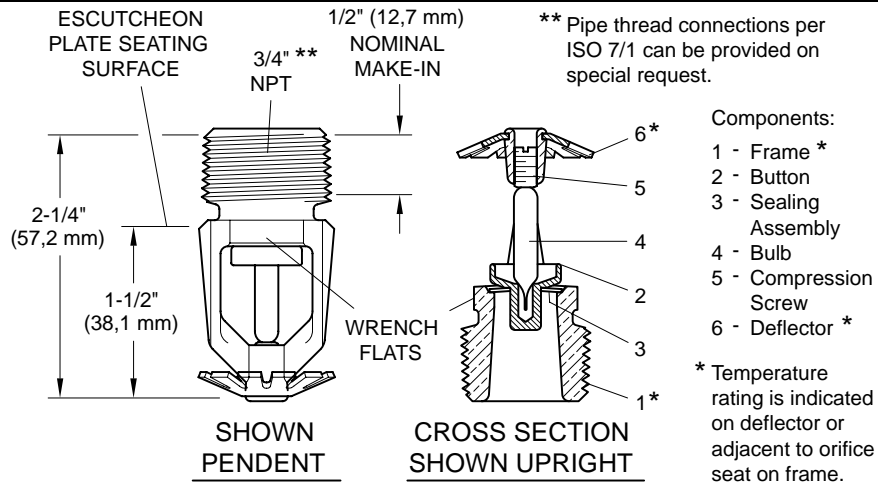

FIGURE 7
STANDARD RESPONSE SERIES TY-B
STAINLESS STEEL CONVENTIONAL (TY9691) SPRINKLERS
8.0 K-FACTOR, 3/4 INCH NPT

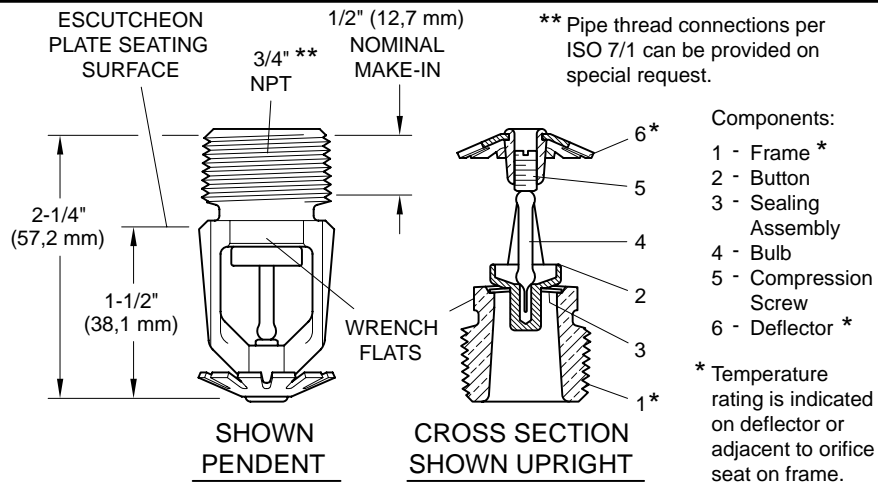
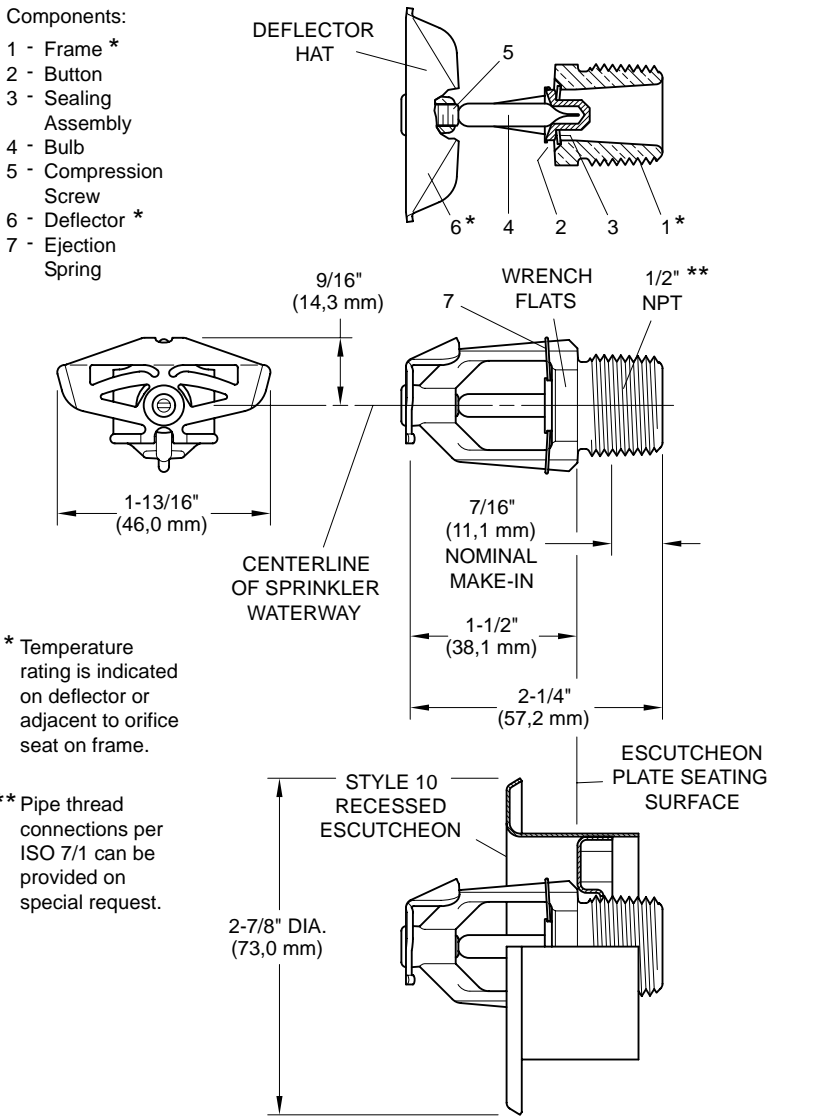

FIGURE 8
QUICK RESPONSE SERIES TY-FRB
STAINLESS STEEL CONVENTIONAL (TY9681) SPRINKLERS
8.0 K-FACTOR, 3/4 INCH NPT

Components:

- 1 - Frame *
- 2 - Button
- 3 - Sealing Assembly
- 4 - Bulb
- 5 - Compression Screw
- 6 - Deflector *
- 7 - Ejection Spring



* Temperature rating is indicated on deflector or adjacent to orifice seat on frame.

** Pipe thread connections per ISO 7/1 can be provided on special request.

FIGURE 9
STANDARD RESPONSE SERIES TY-B
STAINLESS STEEL HORIZONTAL SIDEWALL (TY8391) SPRINKLERS
SMO HORIZONTAL SIDEWALL (TY8392) SPRINKLERS
TITANIUM HORIZONTAL SIDEWALL (TY8393) SPRINKLERS
5.6 K-FACTOR, 1/2 INCH NPT

Operation

The glass bulb contains a fluid which expands when exposed to heat. When the rated temperature is reached, the fluid expands sufficiently to shatter the glass bulb, allowing the sprinkler to activate and water to flow.

Design Criteria

The Tyco® Series TY-B and TY-FRB Sprinklers are intended for fire protection systems designed in accordance with the standard installation rules recognized by the applicable Listing or Approval agency (e.g., UL Listing is based on the requirements of NFPA 13). Only the Style 10 or 40 Recessed Escutcheon, as applicable, is to be used for recessed installations. The Series TY-B and TY-FRB Pendent, Conventional, and Vertical Sidewall Sprinklers are only for non-recessed applications.

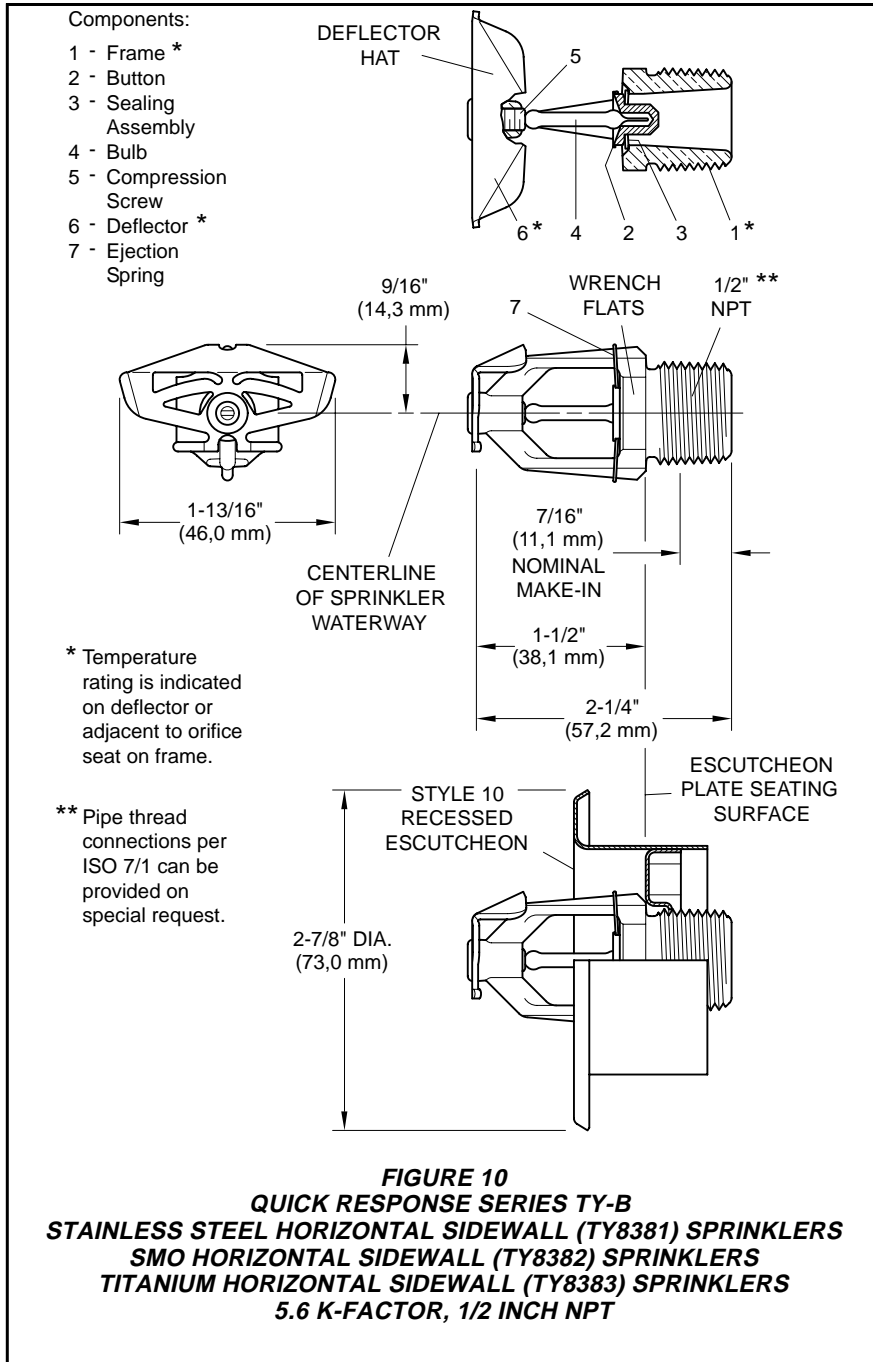

Installation

The Series TY-B and TY-FRB Sprinklers must be installed in accordance with the following instructions:

NOTES

Do not install any bulb type sprinkler if the bulb is cracked or there is a loss of liquid from the bulb. With the sprinkler held horizontally, a small air bubble should be present. The diameter of the air bubble is approximately 1/16 inch (1,6 mm) for the 135°F/57°C to 3/32 inch (2,4 mm) for the 360°F/182°C

temperature ratings.

A 1/2 inch NPT sprinkler joint should be obtained with a minimum to maximum torque of 7 to 14 ft.lbs. (9,5 to 19,0 Nm). A 3/4 inch NPT sprinkler joint should be obtained with a minimum to maximum torque of 10 to 20 ft.lbs. (13,4 to 26,8 Nm). Higher levels of torque may distort the sprinkler inlet and cause leakage or impairment of the sprinkler.

Do not attempt to make-up for insufficient adjustment in the escutcheon plate by under- or over-tightening the

sprinkler. Readjust the position of the sprinkler fitting to suit.

The **Series TY-B and TY-FRB Pendent and Upright Sprinklers** must be installed in accordance with the following instructions.

Step 1A. Pendent sprinklers must be installed in the pendent position, and upright sprinklers are to be installed in the upright position.

Step 2A. With pipe thread sealant applied to the pipe threads, hand tighten the sprinkler into the sprinkler fitting.

Step 3A. Tighten the sprinkler into the sprinkler fitting using only the W-Type 6 Sprinkler Wrench (Ref. Figure 16). With reference to Figures 1, 2, 3, and 4 the W-Type 6 Sprinkler Wrench is to be applied to the wrench flats.

The **Series TY-B and TY-FRB Recessed Sprinklers** must be installed in accordance with the following instructions.

Step 1B. After installing the Style 10 or 40 Mounting Plate, as applicable, over the sprinkler threads and with pipe sealant applied to the pipe threads, hand tighten the sprinkler into the sprinkler fitting,

Step 2B. Tighten the sprinkler into the sprinkler fitting using only the W-Type 7 Recessed Sprinkler Wrench (Ref. Figure 17). With reference to Figures 1, 2, 3, and 4 the W-Type 7 Recessed Sprinkler Wrench is to be applied to the wrench flats.

Step 3B. After the ceiling has been installed or the finish coat has been applied, slide on the Style 10 or 40 Closure over the sprinkler and push the Closure over the Mounting Plate until it comes in contact with the ceiling.

The **Series TY-B and TY-FRB Conventional Sprinklers** must be installed in accordance with the following instructions.

Step 1C. With pipe thread sealant applied to the pipe threads, hand tighten the sprinkler into the sprinkler fitting.

Step 2C. Tighten the sprinkler into the sprinkler fitting using only the W-Type 6 Sprinkler Wrench (Ref. Figure 16). With reference to Figures 5, 6, 7, and 8 the W-Type 6 Sprinkler Wrench is to be applied to the wrench flats.

The **Series TY-B and TY-FRB Horizontal and Vertical Sidewall Sprinklers** must be installed in accordance with the following instructions.

Step 1D. Horizontal sidewall sprinklers are to be positioned in the horizontal position with their centerline of waterway perpendicular to the back

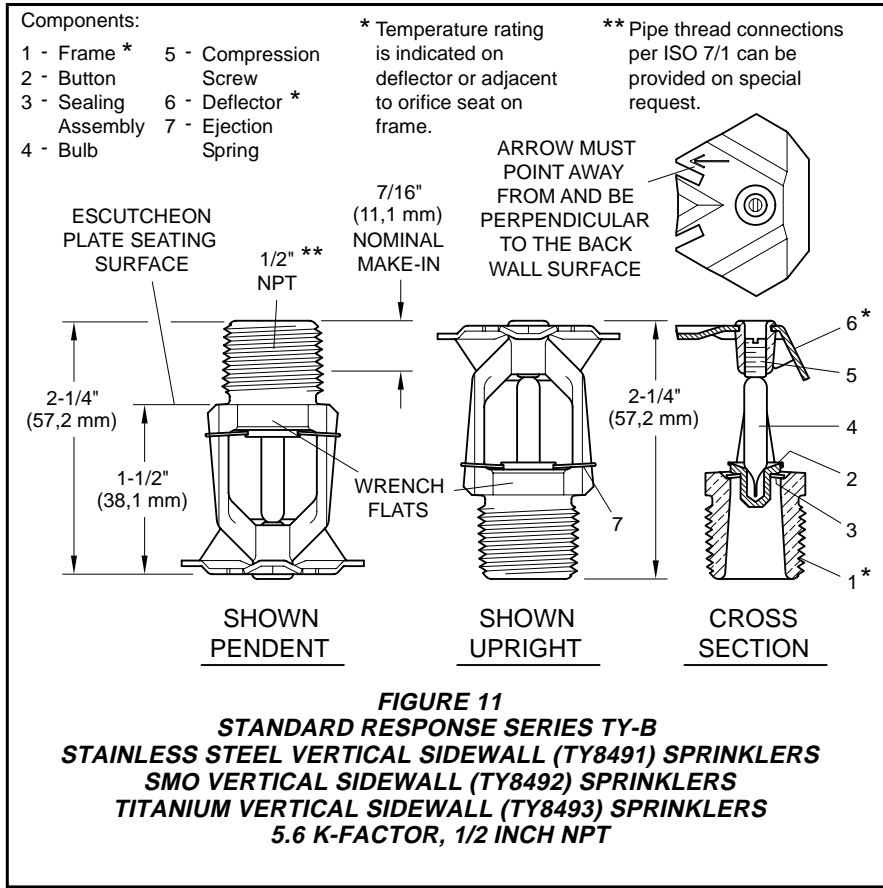

wall and parallel to the ceiling. The word "TOP" on the Deflector is to face towards the ceiling.

Vertical sidewall sprinklers are to be installed in the pendent or upright position with the arrow on the Deflector pointing away from the wall.

Step 2D. With pipe thread sealant applied to the pipe threads, hand tighten the sprinkler into the sprinkler fitting.

Step 3D. Tighten the sprinkler into the sprinkler fitting using only the W-Type 6 Sprinkler Wrench (Ref. Figure 16). With reference to Figures 9, 10, 11, and 12 the W-Type 6 Sprinkler Wrench is to be applied to the wrench flats.

The **Series TY-B and TY-FRB Recessed Horizontal Sidewall Sprinklers** must be installed in accordance with the following instructions.

Step 1E. Recessed horizontal sidewall sprinklers are to be positioned in the horizontal position with their centerline of waterway perpendicular to the back wall and parallel to the ceiling. The word "TOP" on the Deflector is to face towards the ceiling.

Step 2E. After installing the Style 10 Mounting Plate over the sprinkler threads and with pipe thread sealant applied to the pipe threads, hand tighten the sprinkler into the sprinkler fitting.

Step 3E. Tighten the sprinkler into the sprinkler fitting using only the W-Type 7 Recessed Sprinkler Wrench (Ref. Figure 17). With reference to Figures 9 and 10 the W-Type 6 Sprinkler Wrench is to be applied to the wrench flats.

Step 4E. After the wall has been installed or the finish coat has been applied, slide on the Style 10 Closure over the sprinkler and push the Closure over the Mounting Plate until it comes in contact with the wall.

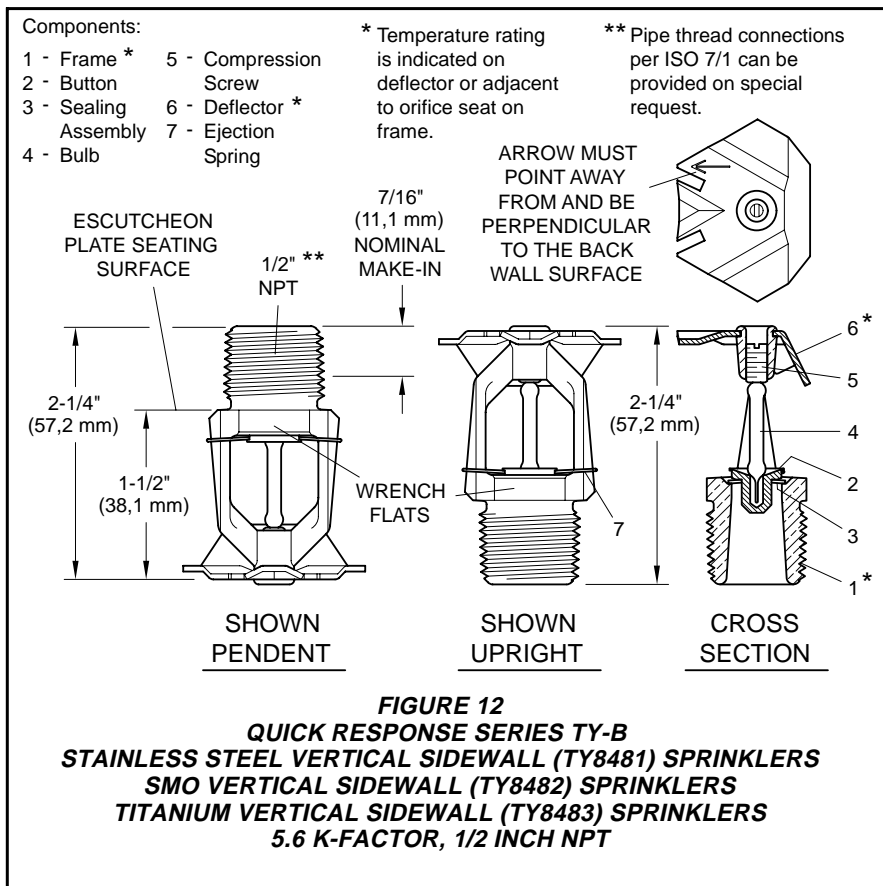

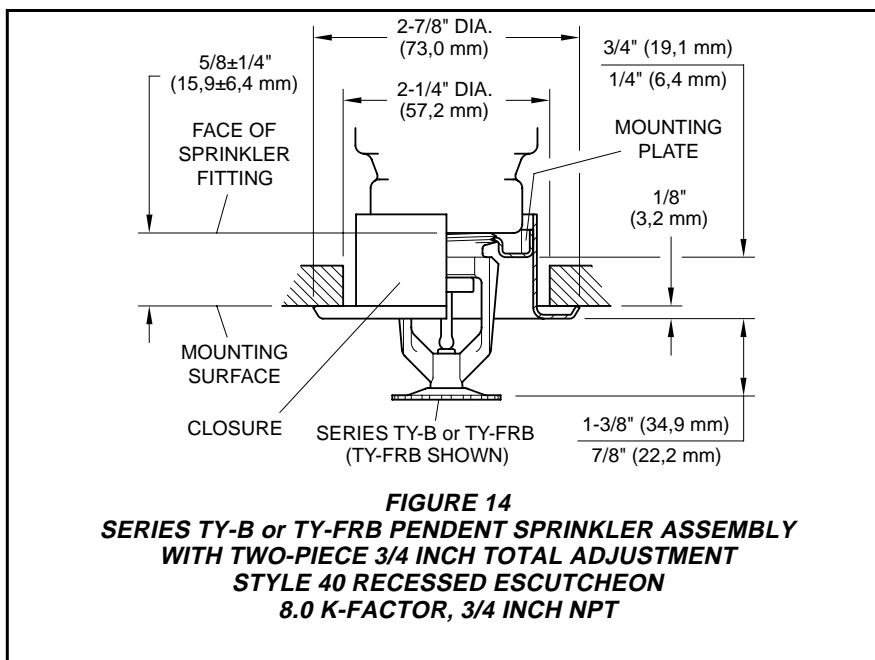
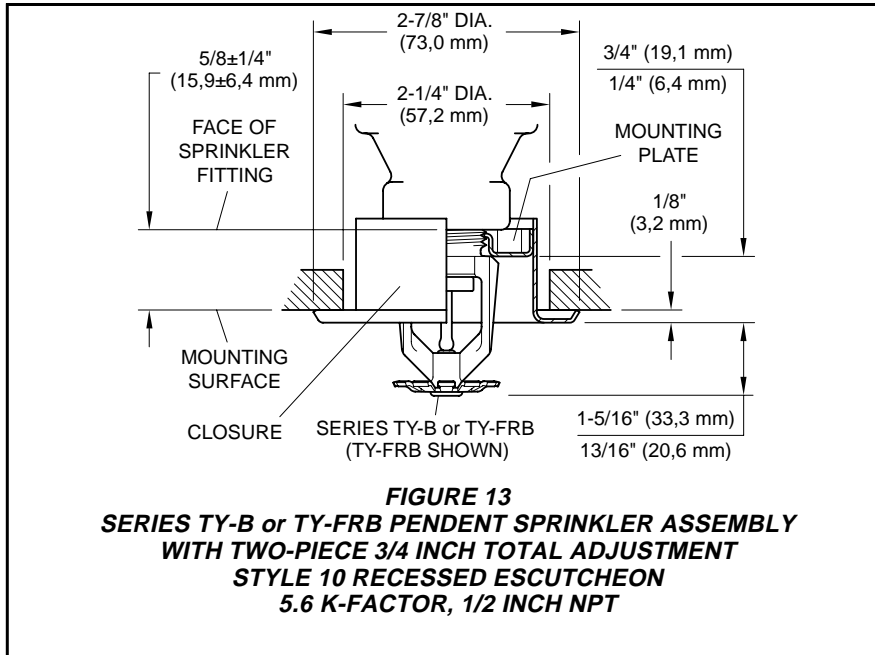

Care and Maintenance

The Tyco® Series TY-B and TY-FRB Sprinklers must be maintained and serviced in accordance with the following instructions:

NOTES

Before closing a fire protection system main control valve for maintenance work on the fire protection system that it controls, permission to shut down the affected fire protection system must be obtained from the proper authorities

and all personnel who may be affected by this action must be notified.

The owner must assure that the sprinklers are not used for hanging of any objects; otherwise, non-operation in the event of a fire or inadvertent operation may result.

Absence of an escutcheon, which is used to cover a clearance hole, may delay the time to sprinkler operation in a fire situation.

Sprinklers that are found to be leaking or exhibiting visible signs of corrosion must be replaced.

Automatic sprinklers must never be painted, plated, coated or otherwise altered after leaving the factory. Modified sprinklers that have been exposed to corrosive products of combustion, but have not operated, should be replaced if they cannot be completely cleaned by wiping the sprinkler with a cloth or by brushing it with a soft bristle brush.

Care must be exercised to avoid damage to the sprinklers - before, during, and after installation. Sprinklers damaged by dropping, striking, wrench twist/slippage, or the like, must be replaced. Also, replace any sprinkler that has a cracked bulb or that has lost liquid from its bulb. (Ref. Installation Section).

Frequent visual inspections are recommended to be initially performed for corrosion resistant sprinklers, after the installation has been completed, to verify the integrity of the corrosion resistant material of construction. Thereafter, annual inspections per NFPA 25 should suffice; however, instead of inspecting from the floor level, a random sampling of close-up visual inspections should be made, so as to better determine the exact sprinkler condition and the long term integrity of the corrosion resistant material of construction, as it may be affected by the corrosive conditions present.

The owner is responsible for the inspection, testing, and maintenance of their fire protection system and devices in compliance with this document, as well as with the applicable standards of the National Fire Protection Association (e.g., NFPA 25), in addition to the standards of any other authorities having jurisdiction. The installing contractor or sprinkler manufacturer should be contacted relative to any questions.

Automatic sprinkler systems should be inspected, tested, and maintained by a qualified Inspection Service in accordance with local requirements and/or national codes.

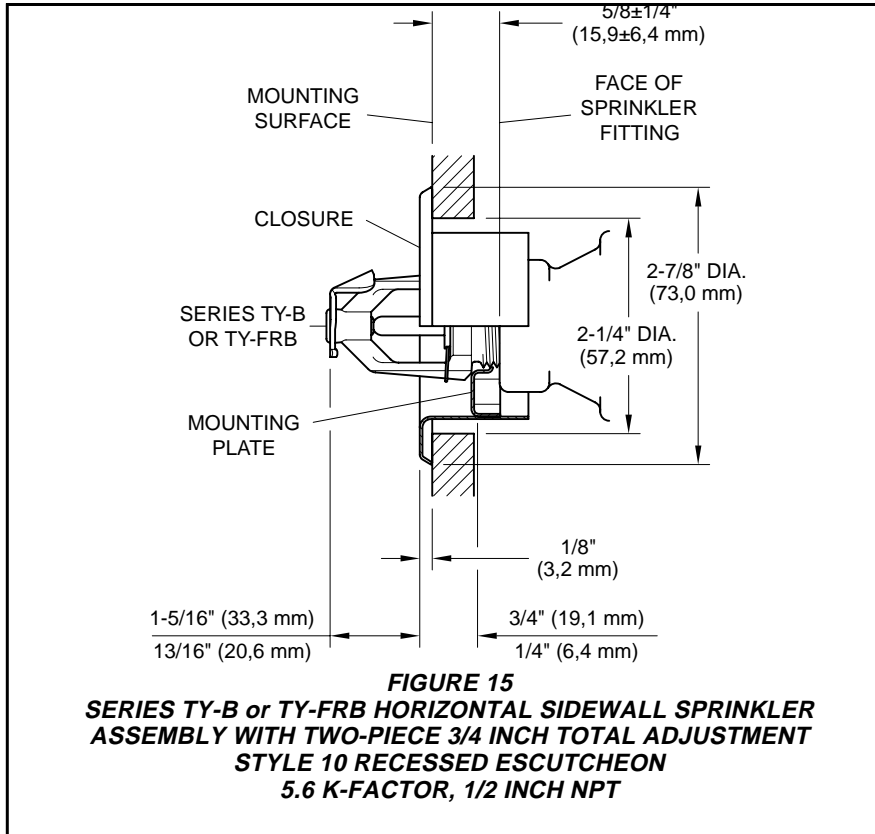

izes any person to assume for it, any other obligation in connection with the sale of products or parts of products. Tyco Fire & Building Products shall not be responsible for sprinkler system design errors or inaccurate or incomplete information supplied by Buyer or Buyer's representatives.

IN NO EVENT SHALL TYCO FIRE & BUILDING PRODUCTS BE LIABLE, IN CONTRACT, TORT, STRICT LIABILITY OR UNDER ANY OTHER LEGAL THEORY, FOR INCIDENTAL, INDIRECT, SPECIAL OR CONSEQUENTIAL DAMAGES, INCLUDING BUT NOT LIMITED TO LABOR CHARGES, REGARDLESS OF WHETHER TYCO FIRE & BUILDING PRODUCTS WAS INFORMED ABOUT THE POSSIBILITY OF SUCH DAMAGES, AND IN NO EVENT SHALL TYCO FIRE & BUILDING PRODUCTS' LIABILITY EXCEED AN AMOUNT EQUAL TO THE SALES PRICE.

THE FOREGOING WARRANTY IS MADE IN LIEU OF ANY AND ALL OTHER WARRANTIES EXPRESS OR IMPLIED, INCLUDING WARRANTIES OF MERCHANTABILITY AND FITNESS FOR A PARTICULAR PURPOSE.

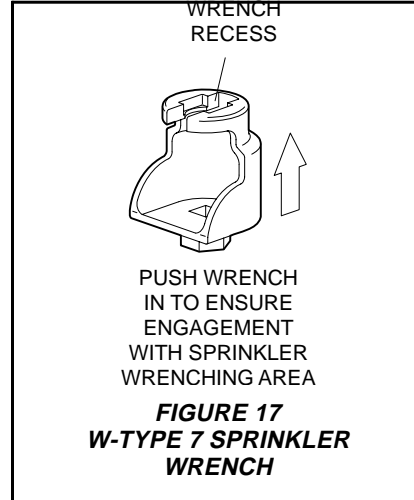
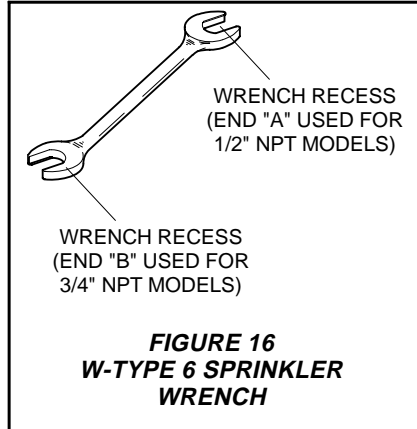

Ordering Procedure

When placing an order, indicate the full product name. Refer to the Price List for complete listing of Part Numbers.

Contact your local distributor for availability.

Sprinkler Assemblies with NPT Thread Connections:

Specify: (Specify Model/SIN), (Specify Standard Response or Quick Response), (specify K-factor), (specify temperature rating), (specify Pendent Upright, C/UP, HSW, or VSW) Sprinkler with (specify type material: Stainless Steel, SMO, or Titanium), P/N (specify from Table E).

Recessed Escutcheon:

Specify: Style (10 or 40) Recessed Escutcheon with (specify material or finish*), P/N (specify).

*Refer to Technical Data Sheet TFP770.

Sprinkler Wrench:

Specify: W-Type 6 Sprinkler Wrench, P/N 56-000-6-387.

Specify: W-Type 7 Sprinkler Wrench, P/N 56-850-4-001.

Limited Warranty

Products manufactured by Tyco Fire & Building Products are warranted solely to the original Buyer for ten (10) years against defects in material and workmanship when paid for and properly installed and maintained under normal use and service. This warranty will expire ten (10) years from date of shipment by Tyco Fire & Building Products. No warranty is given for products or components manufactured by companies not affiliated by ownership with Tyco Fire & Building Products or for

products and components which have been subject to misuse, improper installation, corrosion, or which have not been installed, maintained, modified or repaired in accordance with applicable Standards of the National Fire Protection Association, and/or the standards of any other Authorities Having Jurisdiction. Materials found by Tyco Fire & Building Products to be defective shall be either repaired or replaced, at Tyco Fire & Building Products' sole option. Tyco Fire & Building Products neither assumes, nor author-

P/N 57 — XXX — 0 — XXX — SUFFIX

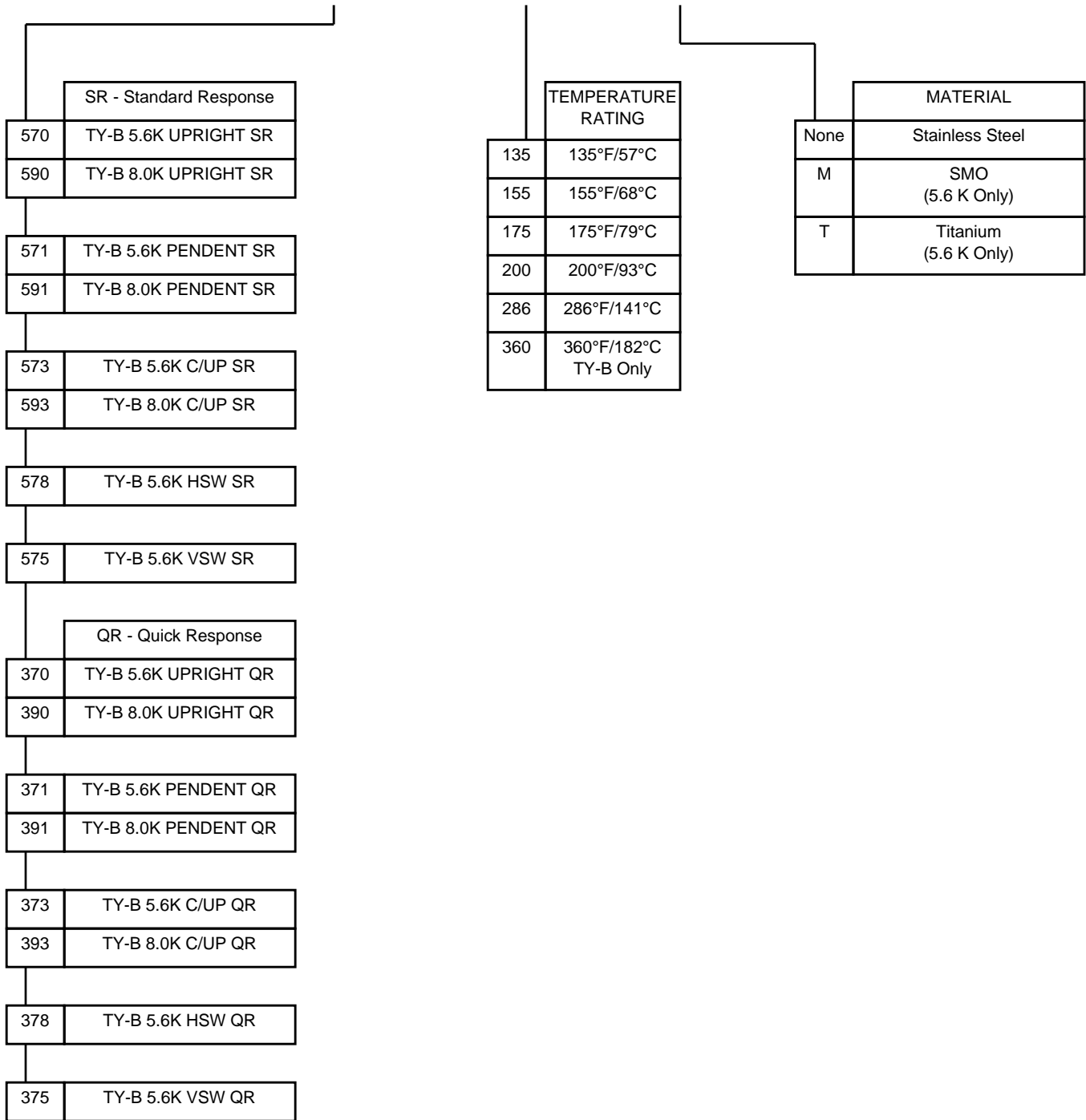

TABLE E
PART NUMBER SELECTION
SERIES TY-B AND TY-FRB SPRINKLERS
ALTERNATE MATERIALS OF CONSTRUCTION